

BOURDON TUBE PRESSURE GAUGE, STAINLESS STEEL WITHOUT / WITH GLYCERINE FILLING ACC. TO EN 837-1



DRUCK & TEMPERATUR

Nominal sizes 100, 160

Connection position bottom or eccentric back

ATEX II 2 GD c IIC T6

For pressure measurement under harsh operating conditions in production plants in the chemical industry and other comparable branches of industry. With glycerine filling in case the measuring system would be protect at pulsation pressure and mechanical vibration against attrition.



Type	6325	6329	6316	6318	Options
Nominal size	100		160		
	fillable				damped measuring mechanism
Symbol					
Accuracy	1,0 acc. to DIN EN 837-1				
Measuring ranges	0...0,6 up to 0...1600 bar, negative and/or positive overpressure				
Applications	Constant load: full of scale value Alternating load: 0,9 x full scale value Overload: 1,3 x full scale value, short time!				
Case	Stainless steel 1.4301 (with blow out)				
Ring	Bayonet, Stainless steel 1.4301				
Movement	Stainless steel 316L (1.4404)				Monel
Connection material	Stainless steel 316L (1.4404)				Monel
Thread	G 1/2 B				M20 x 1,5, 1/2" NPT others in request
Connection position	radial bottom	eccentric back	radial bottom	eccentric back	
Window	Laminated safety glass				
Movement	Stainless steel 1.4301				
Dial	Aluminium white, scale and lettering black				Special scale, double scale
Pointer	Aluminium black				Drag indicator, mark pointer
Temperatures without filling with glycerine filling	Medium: -20°C up to +200°C, ambient/storage: -40°C up to +70°C Medium: -7°C up to +70°C, ambient: -7°C up to +70°C, storage: -20°C up to +70°C				Ambient temp. above -70°C
Mounting options	Rear or front flange, U-Clamp				
Orifice					316L Ø 0,5 mm
Protection class	IP66 / 67 acc. to EN 60529 / IEC 529				
Weight approx.	0,9 kg (with filling 1,2 kg)		1,2 kg (with filling 2,0 kg)		

Dimensional drawing

Dimensions in mm

Type 6325, 6316

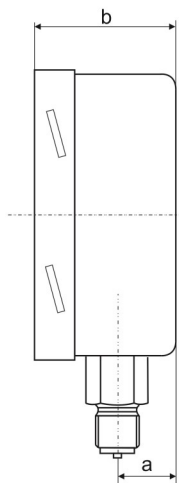
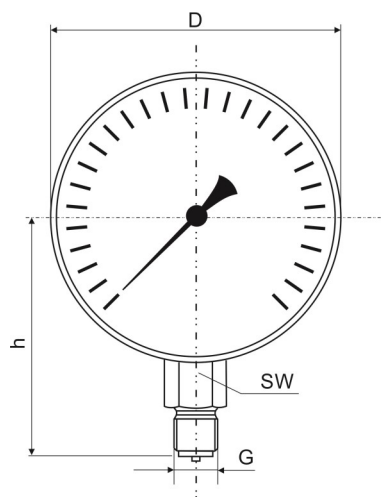

Type 6329, 6318

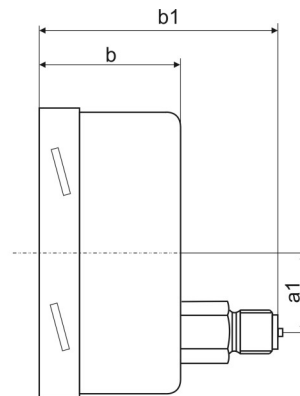

Hole pattern repres. for wall mounting

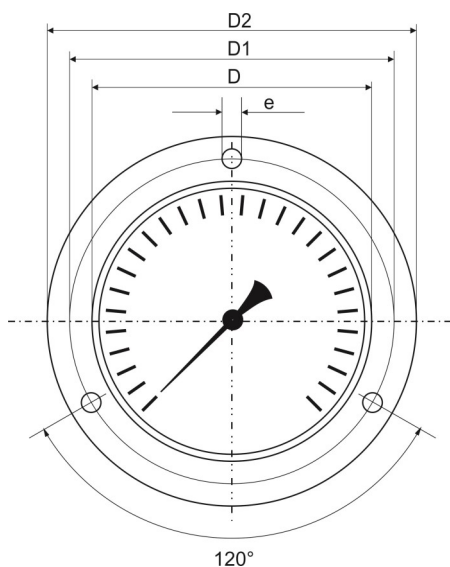

rear flange

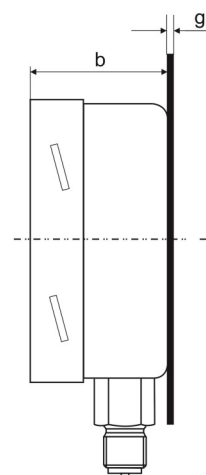

front flange

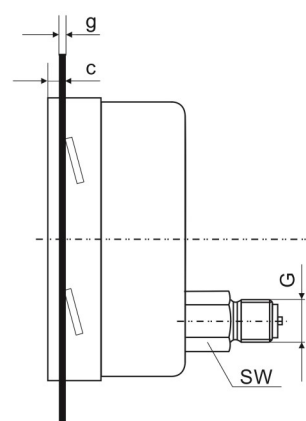

Type	NG	D	G	SW	b	b1	a	a1	h	D1	D2	c	e	g
6325	100	101	G 1/2 B	17	51	-	18,5	-	85	118	132	6	6	2
6329	100	101	G 1/2 B	17	51	86	-	35		118	132	6	6	2
6316	160	161	G 1/2 B	17	50	-	17	-	115	178	196	17	6	2
6318	160	161	G 1/2 B	17	50	85	-	35	-	178	196	17	6	2